



HCT132E

Refrigerated holding
trolley (positive)

CONSTRUCTION FEATURES

- Chamber with radiused corners and removable side racks to facilitate cleaning
- All-around rubber bumpers
- Highly efficient and thick insulation, casing injected with CFC-free polyurethane foam
- Ergonomic and fully built-in door handles with magnetic closure
- Cooling through air-cooled evaporator
- Ecological type compressor unit (R404A)
- Mounted on four 150mm diameter castors, two of which with brake
- Ergonomic handles for pushing and guiding
- Easy access to facilitate maintenance and repair

FUNCTIONAL FEATURES

- Electronic temperature control with defrosting programme
- Simplified, user-friendly controls
- Operating temperature +0°C / +5°C
- Condensate evaporation tray

STANDARD SUPPLY

- Removable GN2/1 and GN1/1 tray racks

OPTIONS & ACCESSORIES

- Stainless steel plate baskets

MODULINESRL

Via dell'Industria 11, Z.I. San Giacomo di Veglia 31029 Vittorio Veneto (TV) - ITALY
 tel. +39 0438 5063 - fax +39 0438 912 323 - info@moduline.it - www.moduline.it



moduline

TECHNICAL INSTALLATION DIAGRAM

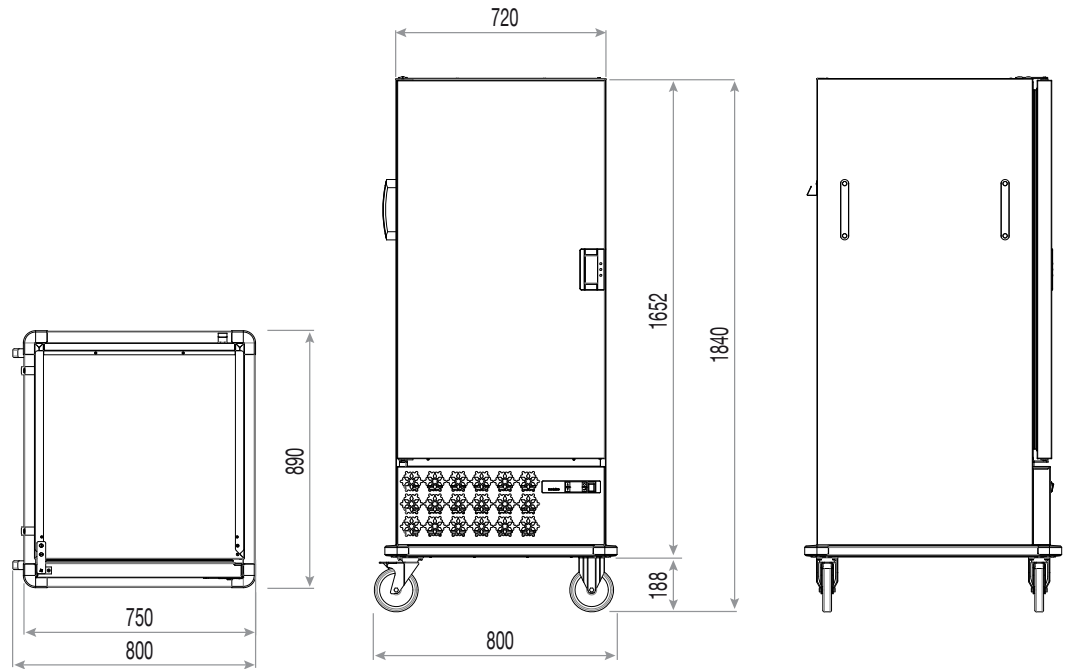

Overall dimensions (W x D x H) - mm	800 x 890 x 1840
Trays capacity	13 x GN 2/1 26 x GN 1/1
Plates capacity plates ø 230-310 containers GN 1/2	48
Power kW	0,65
Power supply	AC 230 V / 50 Hz

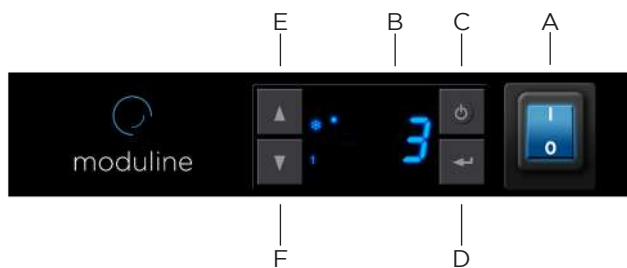

- A ON/OFF switch
- B Display
- C Functions key
- D Enter key
- E Temperature increase key
- F Temperature decrease key

MODULINESRL

Via dell'Industria 11, Z.I. San Giacomo di Veglia 31029 Vittorio Veneto (TV) - ITALY
tel. +39 0438 5063 - fax +39 0438 912 323 - info@moduline.it - www.moduline.it